

Idea bulletin

GLS120 integrally motorized spindles mounted on a hardened way slide

Motorized spindles finish wrist-pin bores to perfection

Application

A transfer line processing automotive engine pistons in groups of four required a compact finishing station for the wrist-pin bore. While the machining done at the station would be light, the location accuracy, inside diameter dimension and surface finish quality had to be “dead on” when the parts left the station.



Challenge

The spindles at each of the four processing positions had to be highly accurate and vibration free to achieve the end user’s surface finish needs. They also

had to be mounted close together and maintain a center-to-center dimension of .001”. Since the four spindles would have to move up to the work

and then back away from it after the operation was complete, a precision slide would be required. Overall reliability of the station had to

meet the “24-7-365” production needs of today’s automotive manufacturing environment.

Solution

Four Gilman GLS120 motorized spindles mounted on a HWL24 “low profile” hardened way slide were chosen as the solution. The spindles featured

flanged-foot housings secured to a precision mounting plate atop the ground ball screw-driven slide. The GLS120 spindles were

extremely low in vibration. Their integral motor design minimized the number of moving parts and the spindle shaft and rotor were precision

balanced before assembly. Precision SKF ABEC 7/9 bearings, a triplex set in the spindle nose and a duplex in the rear, delivered (continued)

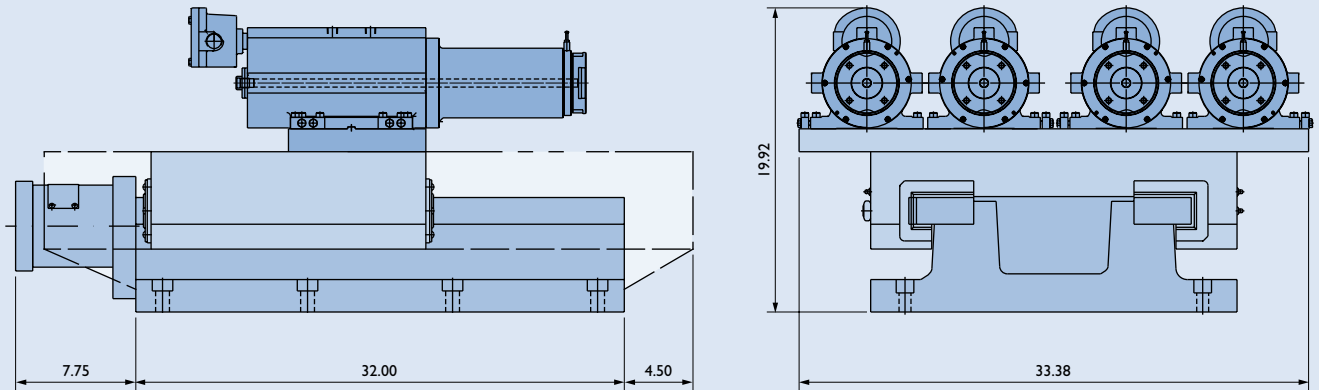

All dimensions in inches unless otherwise indicated.

Solution (continued)

rotational accuracy with a maximum runout of .0001". Liquid cooling of the spindle housing provided a clean and stable environment for the bearings and motor. The

integral motor design of the spindles also contributed to a very compact station. Individual integral motors also helped achieve a control goal for the builder. The ability of the

line to process fewer than the four parts per station was felt to be a key feature that would keep the line running in the event that any of the processing positions at any of the line's

stations went down. The rough cut boring station that preceded this finishing station also featured Gilman USA spindles and slide components.

Technical specifications

HWL24-18-32-D2-12

Slide:

- Base width 24"
- Saddle length 18"
- Travel 12"
- Plumbing for lubrication distribution
- 2,000-.500 R.H. thread ground ball screw - preloaded nut

GLS120 Spindle:

- Nose end, 55mm I.D., light preloaded, triplex set, ABEC 7, 15° angular contact ball bearings
- Drive end, 25mm I.D., medium preloaded, duplex set, ABEC 7, 15° angular contact ball bearings
- Synthetic grease lubrication
- Labyrinth seal on each end
- Operating speed 1,800-8,000 RPM
- Coolant thru-the-spindle shaft
- Tolerances measured at 74° F

Integral motor:

- Totally-Enclosed Liquid-Cooled (TELC) type motor
- Inverter-duty type motor